

PRIMARY MFG

PA-11 MJF

High ductility and Impact strength, Based on 100% renewable sources

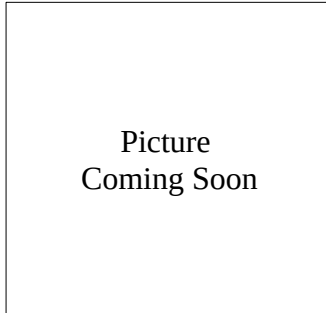

Similar tensile strength to RPU 60, but with far better flexural strength, tolerance to heat, and impact strength. Perfect for applications requiring strength, and nominal flexibility.

Tensile strength 48 MPa

Elongation At break 15-20%

Flexural strength 65-70 MPa

Impact strength 3.5 kJ/m
Notched Izod (machined)

HDT Temperature 175°C

Supported wall thickness

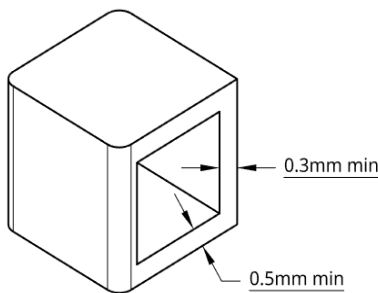

Cantilevers

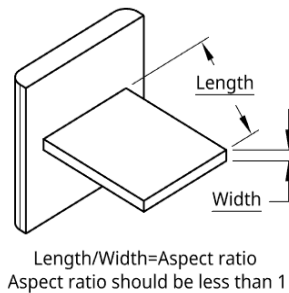

Mating clearance

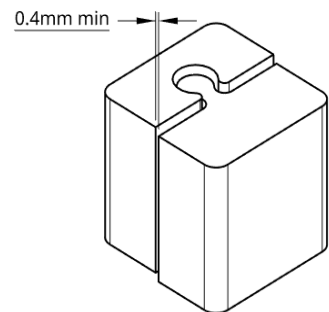

Warping

