

PRIMARY^{MF}

PA-12 MJF

High heat and chemical resistance
 Economical
 Vivid Detail

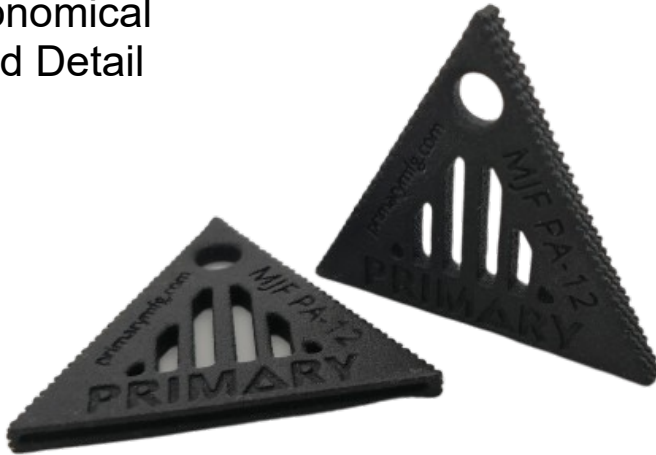

Similar tensile strength to RPU 60, but with far better flexural strength, tolerance to heat, and impact strength. Perfect for applications requiring strength, and nominal flexibility.

Tensile strength 48 MPa

Elongation At break 15-20%

Flexural strength 65-70 MPa

Impact strength 3.5 kJ/m
Notched Izod (machined)

HDT Temperature 175°C

Supported wall thickness

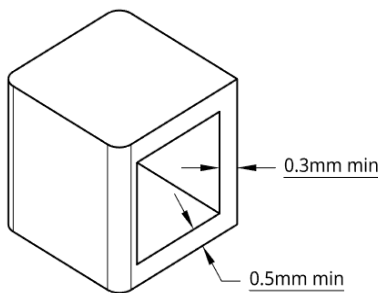

Cantilevers

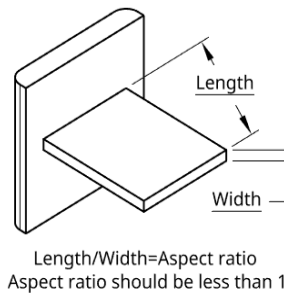

Mating clearance

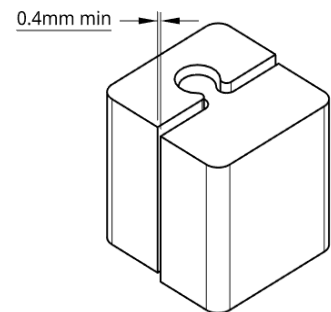

Warping

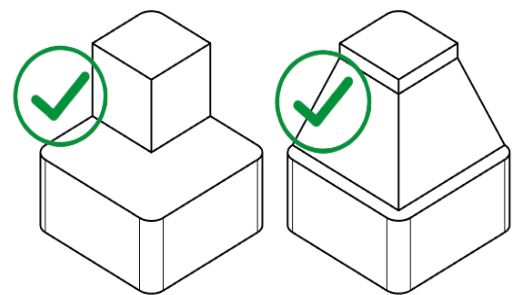
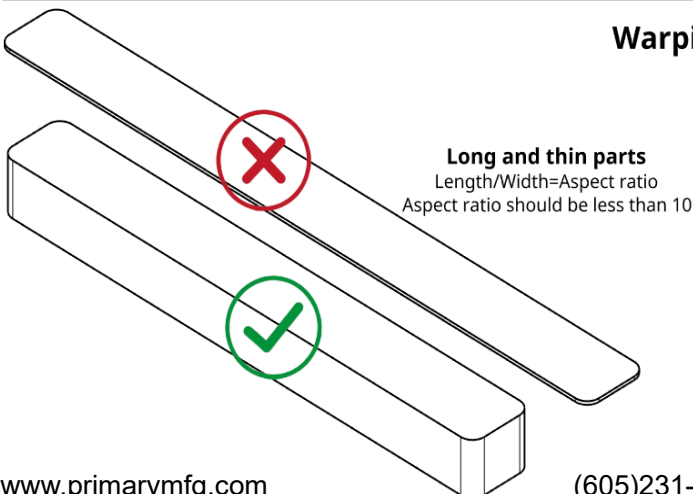

Abrupt changes in cross-section
 Smooth transitions help to avoid warping and other issues